

Suggested minimum clearances assuming a grinder placed to the right of the machine.

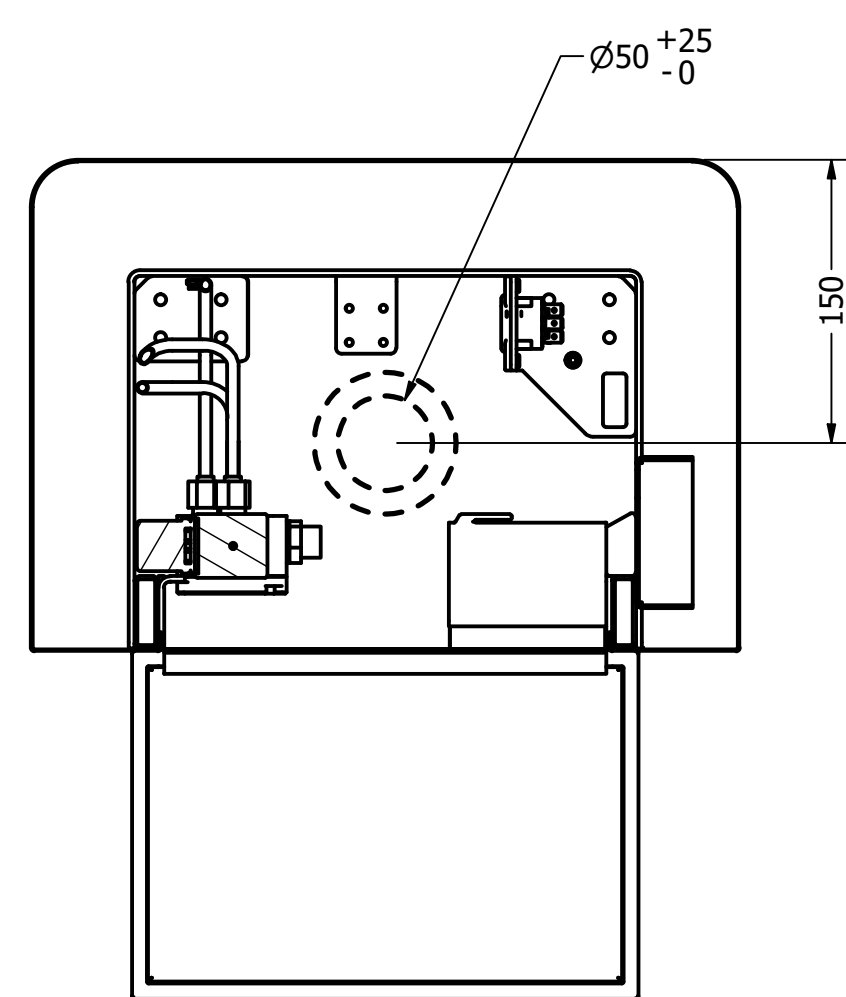

Location of $\varnothing 50$ -75mm [2-3"] countertop cutout for drain, electrical and water supply.

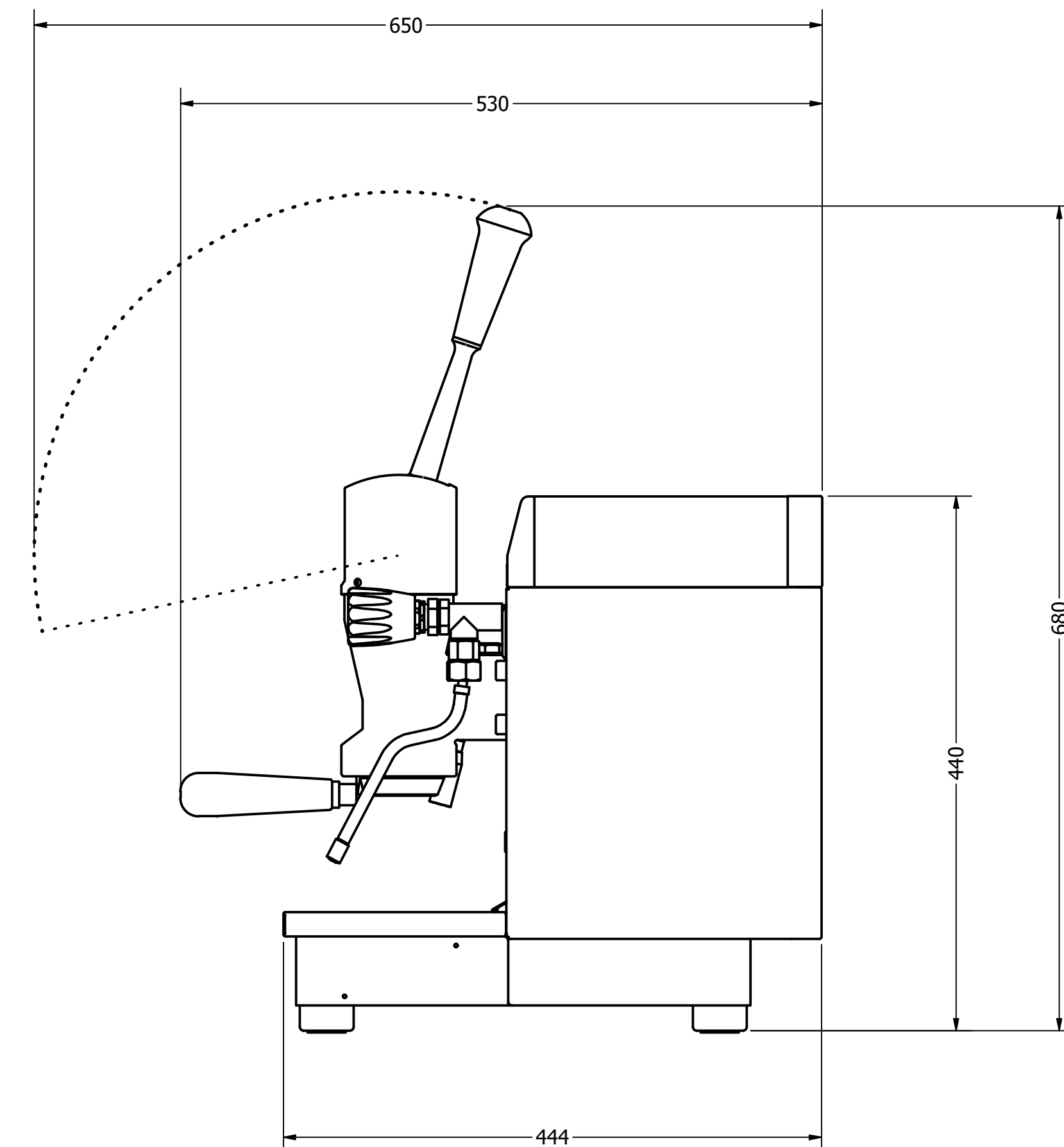
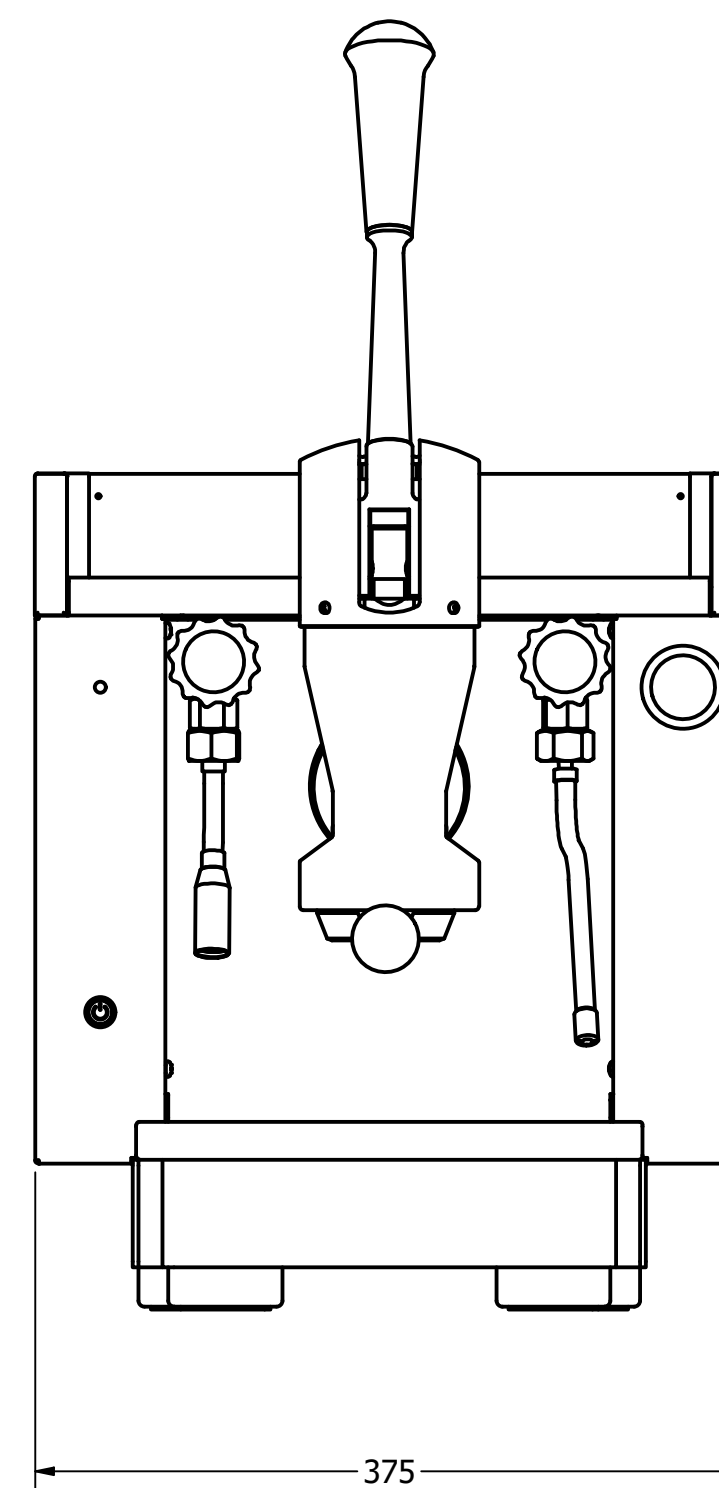

REVISION HISTORY				
ZONE	REV	DESCRIPTION	DATE	APPROVED
	2		10/25/2024	tsm

DRAWN tsm MASS 32.199 kg MATERIAL FINISH STANDARD TOLERANCE (UNLESS OTHERWISE SPECIFIED) DECIMAL .X ± 0.1 ANGULAR X ± 0.25° .XX ± 0.05 .XXX ± 0.013	<h1>Lapera</h1>	TITLE DWG NO lapera_v07.2_installation VER 2
SCALE	UNITS	SHEET 1 OF 1